

Build-it-yourself construction plans - #SBE 0500



Hive bodies and honey supers are probably the most popular woodworking project for new beekeepers. They're easy to make and you can always use a few more than you think you need especially during "swarm season." This design uses regular 3/4" lumber with rabbeted corners instead of box joints. They can be built by anyone with basic woodworking tools and skills. The illustrations show honey super construction but dimensions and instructions for deep supers are included.

These plans include:

Materials and cut list

Detailed drawings

Photographs

Assembly instructions

Metric conversion table

Required Tools:

This project can be built using only a table saw and a router with a 3/4" straight bit.

Super Structure

This stack of deep supers shows the typical mix of commercially produced and home-built supers found in many apiaries. Note the various styles of hand holds and corner joints.



Commercially built supers are made from 7/8" thick lumber and use box joints at the corners for strength. Home-built supers made from regular 3/4" thick lumber and rabbet joints that are properly glued and screwed will last for years if properly treated. Plan to build several at the same time.

*Note: All Stonehaven Plans are sold with the understanding that they are for the specified use only by the purchaser. The purchaser has agreed that they will not be copied, sold or otherwise re-distributed without written permission. These FREE plans for honey supers and hive bodies may be copied and re-distributed in their original form only.

Materials

Wood

You can make supers out of dimensional lumber (like pine, cedar, cypress, etc.) or from $\frac{3}{4}$ " exterior grade plywood. Plywood supers are a bit heavier and can de-laminate over time unless they're kept well painted. Dimensional lumber may be a bit more expensive. You'll need 1" x 8" lumber for honey supers (6 $\frac{5}{8}$ " h) and 1" x 12" lumber for deep supers (9 $\frac{1}{2}$ " h). Alternatively, you could glue 2" strips to full-width 1x8 for deep supers. Look for good quality boards with few (tight) knots. Plan on using (1) eight-foot length for each super.

Hardware

The corners are fastened with 1 $\frac{1}{2}$ " wood screws (brass are best). You'll also need two metal frame rests for each super. These keep the frame from being permanently glued into place with propolis by the "girls" and allow the frames to slide more easily within the super. These are available through any beekeeping supply store or they can be fabricated from sheet metal.

Honey/Deep Super Dimensions **Fig. 1**

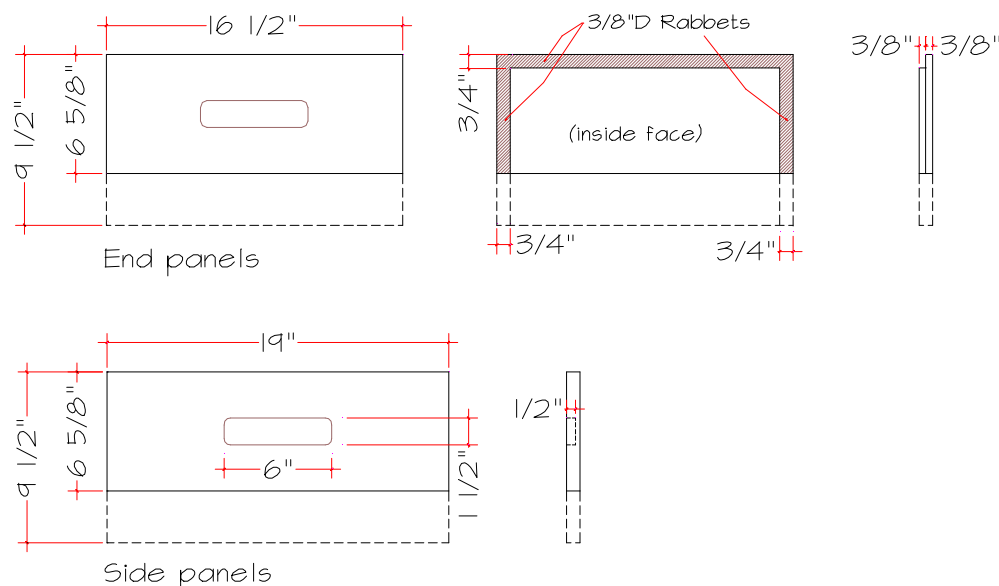

Cut list

Rip 1 x 8 lumber to 6 $\frac{5}{8}$ "w for honey supers --- (1) - six to eight-foot length per super

Rip 1 x 12 lumber to 9 $\frac{1}{2}$ "w for deep supers --- (1) - six to eight-foot length per super

Here's what you should have when the sawdust settles:

Honey supers:

Deep supers:

End panels (2) – 16 1/2" x 6 5/8"

(2) – 16 1/2" x 9 1/2"

Side panels (2) – 19" x 6 5/8"

(2) – 19" x 9 1/2"

Procedure

Sanding

Start by sanding the end cuts of all the panels. Clamp several panels together to make a broader surface when sanding. This helps to avoid rounded edges and makes them all a uniform size.

End panels

The $3/8"$ x $3/4"$ rabbet joints are cut in the end panels and are cut on the table saw. The vertical cut should be done first. Set the fence $3/8"$ from the inside of the blade and set the blade height to $3/4"$. Use a featherboard to keep the panel snug against the fence (Fig. 2). It helps to use a tall auxiliary fence to keep the panel vertical. Make cuts at both ends and along the top of each panel keeping the outside face against the fence.

Remove the featherboard and adjust the fence to $3/4"$ from the outside of the blade. Lower the blade height to $3/8"$. With the outside face up, complete the rabbet cuts (Fig. 3).



Fig. 2

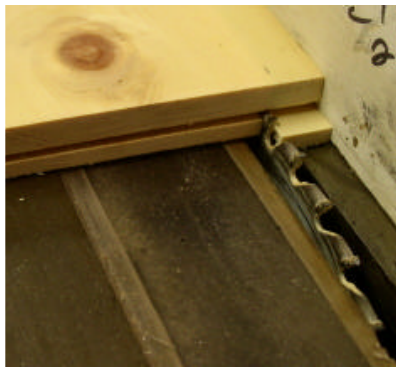

Fig. 3



Fig. 4 Inside of rabbeted end panel

Hand hold template

Use a router with a $3/4"$ straight bit to cut the $1/2"$ deep hand holds. Make a template from a piece of $1/4"$ plywood or Masonite (Fig. 5). I made mine the same size as the end panel of a deep super and marked centering lines along the edges. The opening dimensions given are for a router with a 6" base and allow for a slight overlap. You'll need to make 2 or 3 shallow passes to get the to the final depth.

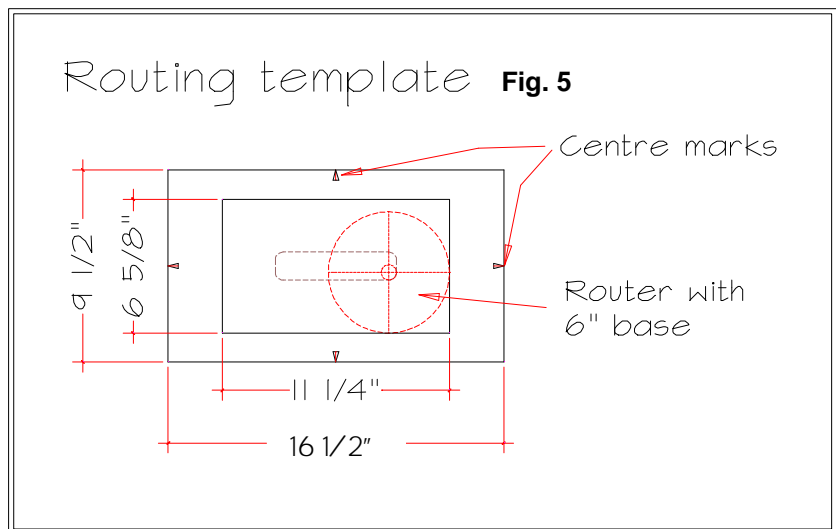

Routing the handholds

Centre the template on the outside face of the panel and clamp it securely. Set the router bit to a depth of about 3/16" or 1/4" and make the first pass keeping the base against the template and going counter clockwise. Increase the bit exposure and repeat until you get to the 1/2" depth (Fig. 6). All four sides of each super should have a hand hold.



Fig. 6

Alternate handhold method

If you have a dado blade for your table saw you can also cut hand holds using a stopped dado method. These should also be about 6" L x 1 1/2" W x 1/2" D.

Assembly

The panels are fastened with waterproof wood glue and 1 1/2" screws. You'll also need to have a couple of F-clamps handy (at least 18" capacity). Dry fit the panels together and check that the corners will line up properly. Apply glue to the corner rabbets of the end panels. Assemble all the panels and clamp them together with clamps across the width of the super (Fig. 7). Check that the corners are square and screw the end panels to the sides. Use at least three screws on each corner for honey supers and five for deep supers.

Frame rests

Drill or punch three small holes in each metal frame rest. This makes it easier to nail them into place with 3/4" nails. Fig. 8 shows how the frame will sit in the super.

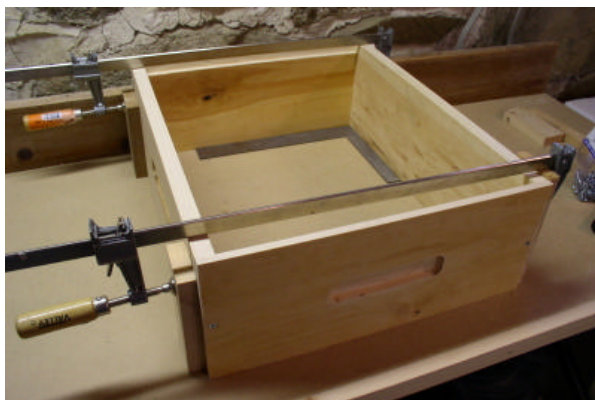

Fig. 7

Painting

Give each super a final sanding, especially the exposed end grain at the corners. Prime the outside and the top and bottom edges with an exterior primer and topcoat with a good quality latex paint. The inside should not be painted.

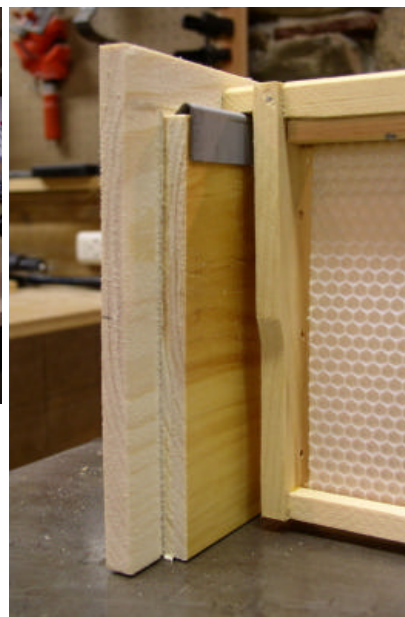

Fig. 8

Tip: The edges and corners of supers can get damaged through normal wear and tear. Use autobody filler to repair chipped or gouged corners and edges. For a severely damaged corner, use a couple of small nails with the heads slightly raised to give the body fill something to hold onto. Apply the filler, let it dry, sand it and paint.

Metric Conversion

These plans were developed using Imperial measurements, which are in common use in Canada and the United States. In North America, a typical 1" x 8" board is in reality, planed to 3/4" x 7 1/2" (19 mm x 190 mm). The table below provides all the relevant conversions to complete the project using metric equivalents.

Metric Conversion Table

Description	Page	Inches	Millimetres
Honey super			
End panels	2	16 1/2" x 6 5/8"	419 mm x 170 mm
Side panels	2	19" x 6 5/8"	483 mm x 170 mm
Deep super			
End panels	2	16 1/2" x 9 1/2"	419 mm x 241 mm
Side panels	2	19" x 9 1/2"	483 mm x 241 mm
Other Key Measurements			
Rabbets	2	3/8" x 3/4"	9.5 mm x 19 mm
Handholds (L x W x D)	2	6" x 1 1/2" x 1/2"	152 mm x 38 mm x 12.5 mm
Template cut-out	3	6 5/8" x 11 1/4"	170 mm x 285.5 mm
Screws	2	1 1/2"	38 mm

Note: All conversions rounded off to closest decimal point. 1 inch = 25.4 mm.



BEE-Mate Field Stand

8pps – US\$4.00

This handy “Beekeeper’s Helper” is a convenient work stand to set down supers, with a rack to hang up frames — whether you’re making up nucs, sorting frames, or just checking in on the “girls” during swarm season.

The BEE-Mate field stand’s **18-inch height makes beekeeping easier on your back and knees**, especially when you’re working with supers loaded with honey.



The Honey Money Bank

6pps – US\$2.50

a unique and practical craft project suitable for anyone with basic woodworking skills and tools. If you’re a beekeeper, it also makes a great value-added gift package for small jars of honey.

Whether you fill it with honey or money, the Honey Money bank makes a great afternoon project as well as a gift for any occasion.

This project can be built using only a table saw and a table-mounted router.



Roadside Honey Stand

20pps – US\$15.00

Looking for a way to sell your surplus honey? Why not let it “sell itself” in your own self-serve Roadside Honey Stand.

The Stonehaven Roadside Honey Stand operates on the honour system—enabling your customers to serve themselves – even when you’re not home. Your customers will love the novelty and the good feeling that comes with it—which will pay off in great word-of-mouth advertising and repeat sales.



Bee Hive Planter

Free PDF Download

a unique way bring a beekeeping theme into your home garden.

It’s made using a standard bottom board, deep super and a medium super. The cap is built to resemble a conventional hive cover. The open center allows access to one or more potted plants which sit on a shelf.

Easy to build! No special tools required.

Future plans include... nuc boxes – feeder entrances – specialty inner covers and more!